



Screw free fixing spacer is combined with EMC grounding function.

Feature

- Grounding at the center of the PC board is easily achieved.
- Suitable for total cost downsizing through high workability and reduction of part numbers.

Material

- Plastic portion / PPHOX (Black / UL94V-0)
- Metal portion / Phosphor bronze (Sn plating)

Installation specifications

- (a): Board thickness/t=1.6~2.0mm
Hole diameter/ $\phi 4.0^{+0.1}$ mm
- (b): Board thickness/t=1~2.0mm
Hole diameter/ $\phi 4.8^{+0.1}$ mm

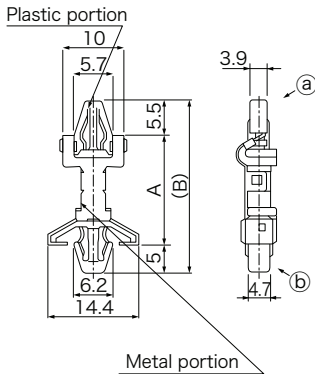

Unit: mm

Part No.	A	(B)
FGS-3S	9.8	20.3
FGS-4S 1	11.4	21.9
FGS-6S	14.4	24.9
FGS-8S	17.7	28.2
FGS-9S	20.0	30.5

FG EDGE SPACER/FGES-10



EMC grounding function is added to the spacer whose specialty lever system enables easy fixing and removal of PC board.

Feature

- Easy fixing, opening and closing of PC board are provided as well grounding function.
- The flux which is on the metal contact surface on the chassis side can be removed when fixing.
- High workability and reduction of part numbers enable total cost downsizing.

Material

- Plastic portion / PPHOX Black / UL94V-0
- Metal portion / Phosphor bronze (Sn plating)

Installation specifications

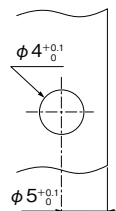
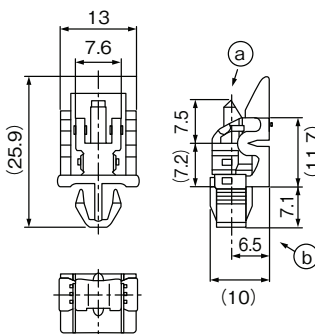

Board side: t1.6±0.15

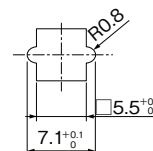

Chassis side: t0.8~2.3

Unit: mm